

ITEM NO.	PART NUMBER	DESCRIPTION	QTY.
1	BB3CF-S01	BLANK BODY, 3"1502 FEMALE STD 15K	1
2	USR3-S01	SEAL RING, 3"602/1002/1502 STD BUNA 90	1

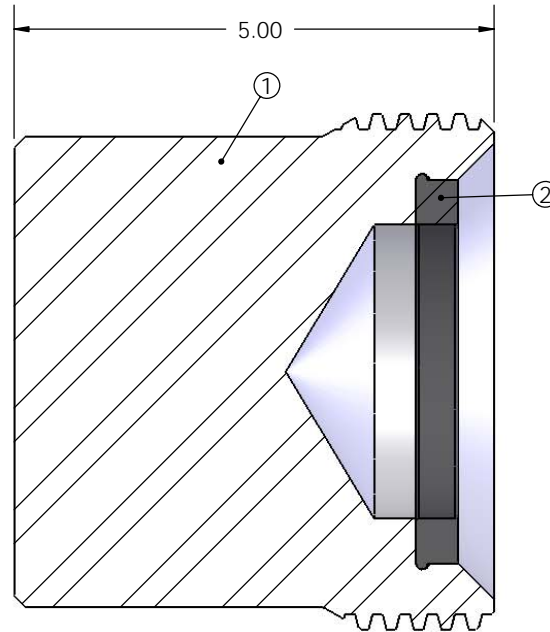

SECTION A-A
SCALE 1 : 2

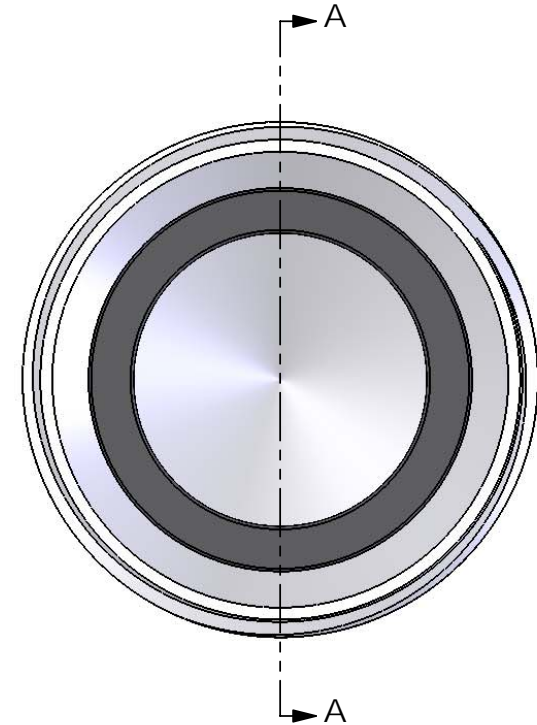

DRAWING STANDARDS:

- DIMENSION UNITS ARE INCHES
 1. ALL CORNER RADII R0.30
 2. BREAK ALL EDGES 0.015 X 45° OR R.015
 3. HIGBEE ALL ACME THREADS TO FULL WIDTH
 4. REFERENCE DIMENSIONS ARE IN PARENTHESIS
 5. MACHINED SURFACES ARE 125 Ra
 6. ALL DIAMETERS CONCENTRIC AND ROUND TO ± 0.005
 7. TOLERANCES: .XX ±0.015 < ±0.5°
 .XXX ±0.005

- < ±0.5° // PARALLELISM
 ○ ROUNDNESS ⊥ PERPENDICULARITY
 ◎ CONCENTRICITY ↗ RUNOUT
 ⊕ CYLINDRICITY ⊓ COUNTERBORE
 ▱ FLATNESS ∨ COUNTERSINK

TOLERANCES: .XX ±0.015
 .XXX ±0.005
 < ±0.5°
 UNLESS OTHERWISE STATED

ECN NO:	CHANGES INCLUDE:		
ECN DATE:			
MATERIAL SPEC:	TITLE: BLANK ASSY, 3"1502 FEMALE STD 15K		REVISION: 0
RAW MATERIAL DESC:	DWG NO. BA3CF-S01		DATE: 7/24/2008
WEIGHT: 23.00	DRAWN BY: SR	CHK'D: JF	APP'VD: KB
			SHEET 1 OF 1

DO NOT SCALE DRAWING

THIS DRAWING IS PROPRIETARY AND CONFIDENTIAL PROPERTY. THIS DOCUMENT CANNOT BE REPRODUCED OR DISTRIBUTED WITHOUT THE WRITTEN CONSENT OF PHOINIX GLOBAL LLC.