

**DRAWING STANDARDS:**

- 1. ALL CORNER RADII R0.03
- 2. BREAK ALL EDGES 0.015 X 45° OR R.015
- 3. HIGBEE ALL ACME THREADS TO FULL WIDTH
- 4. REFERENCE DIMENSIONS ARE IN PARENTHESIS
- 5. MACHINED SURFACES ARE 125 Ra
- 6. ALL DIAMETERS CONCENTRIC AND ROUND TO ± 0.005
- 7. TOLERANCES: .XX ±0.015 <math>\leq \pm 0.5^\circ</math>  
.XXX ±0.005

- $\angle \pm 0.5^\circ$
- $\parallel$  PARALLELISM
- $\bigcirc$  ROUNDNESS
- $\perp$  PERPENDICULARITY
- $\odot$  CONCENTRICITY
- $\curvearrowright$  RUNOUT
- $\text{C}$  CYLINDRICITY
- $\sqcup$  COUNTERBORE
- $\square$  FLATNESS
- $\nabla$  COUNTERSINK

TOLERANCES: .XX ±0.015  
.XXX ±0.005  
 $\leq \pm 0.5^\circ$   
UNLESS OTHERWISE STATED

ECN NO:	CHANGES INCLUDE:		
ECN DATE:			
MATERIAL SPEC:		TITLE: LATERAL, 1502 4"F/3"F/4"M STD 15K 45DEG	REVISION: 0
RAW MATERIAL DESC:		DWG NO. FLAC4F3F4M-S01	DATE: 10/3/2006
WEIGHT: 240.05	DRAWN BY: KB	CHK'D: JF	APPV'D: SR
			SHEET 1 OF 2

DO NOT SCALE DRAWING

THIS DRAWING IS PROPRIETARY AND CONFIDENTIAL PROPERTY. THIS DOCUMENT CANNOT BE REPRODUCED OR DISTRIBUTED WITHOUT THE WRITTEN CONSENT OF PHOINIX GLOBAL LLC.

ITEM NO.	PART NUMBER	DESCRIPTION	QTY.
1	FLBC4F3F4M-S01	LATERAL BODY, 1502 4"F/3"F/4"M STD 15K 45DEG	1
2	UWN-4C-D-S	WINGNUT, 4"1502 STD 15K DETACHABLE	1
3	UNRC4	NUT RETAINER, 4"1502	1
4	URRC4	RETAINER RING, 4"1502	1
5	USR3-S01	SEAL RING, 3"602/1002/1502 STD BUNA 90	1
6	USR4-S01	SEAL RING, 4"602/1002/1502 STD BUNA 90	1

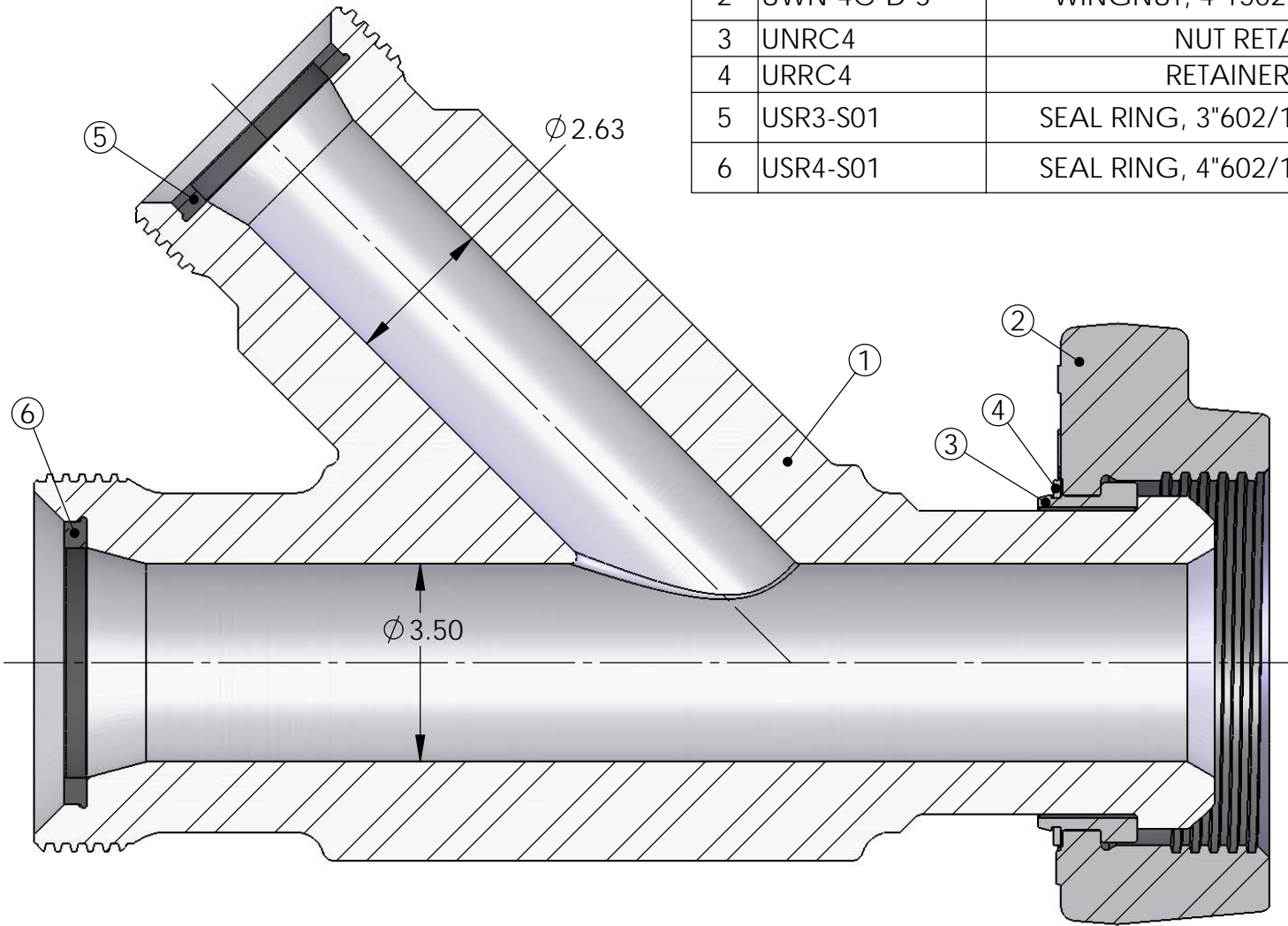

**DRAWING STANDARDS:**

DIMENSION UNITS ARE INCHES

1. ALL CORNER RADII R0.03
2. BREAK ALL EDGES 0.015 X 45° OR R.015
3. HIGBEE ALL ACME THREADS TO FULL WIDTH
4. REFERENCE DIMENSIONS ARE IN PARENTHESIS
5. MACHINED SURFACES ARE 125 Ra
6. ALL DIAMETERS CONCENTRIC AND ROUND TO ± 0.005
7. TOLERANCES: .XX ± 0.015 < ± 0.5°  
.XXX ± 0.005

- < ± 0.5°
- ROUNDNESS
- ◎ CONCENTRICITY
- ⊘ CYLINDRICITY
- ▭ FLATNESS
- // PARALLELISM
- ⊥ PERPENDICULARITY
- ↗ RUNOUT
- COUNTERBORE
- ∨ COUNTERSINK

TOLERANCES: .XX ± 0.015  
.XXX ± 0.005  
< ± 0.5°  
UNLESS OTHERWISE STATED

ECN NO:

CHANGES INCLUDE:

ECN DATE:

MATERIAL SPEC:

RAW MATERIAL DESC:

WEIGHT: 240.05

TITLE: LATERAL, 1502 4"F/3"F/4"M STD 15K 45DEG

DWG NO. FLAC4F3F4M-S01

DRAWN BY: KB

CHK'D: JF

APPV'D: SR

REVISION:

0

DATE:

10/3/2006

SHEET 2 OF 2

DO NOT SCALE DRAWING

THIS DRAWING IS PROPRIETARY AND CONFIDENTIAL PROPERTY. THIS DOCUMENT CANNOT BE REPRODUCED OR DISTRIBUTED WITHOUT THE WRITTEN CONSENT OF PHOINIX GLOBAL LLC.