

DRAWING STANDARDS:		TOLERANCES: .XX ±0.015	
DIMENSION UNITS ARE INCHES		.XXX ±0.005	
1. ALL CORNER RADII R0.30	∠ ±0.5°	// PARALLELISM	UNLESS OTHERWISE STATED
2. BREAK ALL EDGES 0.015 X 45° OR R.015	○ ROUNDNESS	⊥ PERPENDICULARITY	
3. HIGBEE ALL ACME THREADS TO FULL WIDTH	◎ CONCENTRICITY	↗ RUNOUT	
4. REFERENCE DIMENSIONS ARE IN PARENTHESIS	⊘ CYLINDRICITY	⊓ COUNTERBORE	
5. MACHINED SURFACES ARE 125 Ra	∇ FLATNESS	∇ COUNTERSINK	
6. ALL DIAMETERS CONCENTRIC AND ROUND TO ± 0.005			
7. TOLERANCES: .XX ±0.015 ∠ ±0.5°			
.XXX ±0.005			

ECN NO:	CHANGES INCLUDE:		
ECN DATE:			
MATERIAL SPEC:	TITLE: TEE, 4"1502 FMM STD 15K		REVISION: 0
RAW MATERIAL DESC:	DWG NO. FTAC4FMM-S01		DATE: 5/10/2006
WEIGHT: 211.02	DRAWN BY: SR	CHK'D: JF	APP'VD: KB
			SHEET 1 OF 2

DO NOT SCALE DRAWING

THIS DRAWING IS PROPRIETARY AND CONFIDENTIAL PROPERTY. THIS DOCUMENT CANNOT BE REPRODUCED OR DISTRIBUTED WITHOUT THE WRITTEN CONSENT OF PHOINIX GLOBAL LLC.

ITEM NO.	PART NUMBER	DESCRIPTION	QTY.
1	UWN-4C-D-S	WINGNUT, 4"1502 STD 15K DETACHABLE	2
2	UNRC4	NUT RETAINER, 4"1502	2
3	URRC4	RETAINER RING, 4"1502	2
4	USR4-S01	SEAL RING, 4"602/1002/1502 STD BUNA 90	1
5	FTBC4FMM-S01	TEE BODY, 4"1502 FMM STD 15K	1

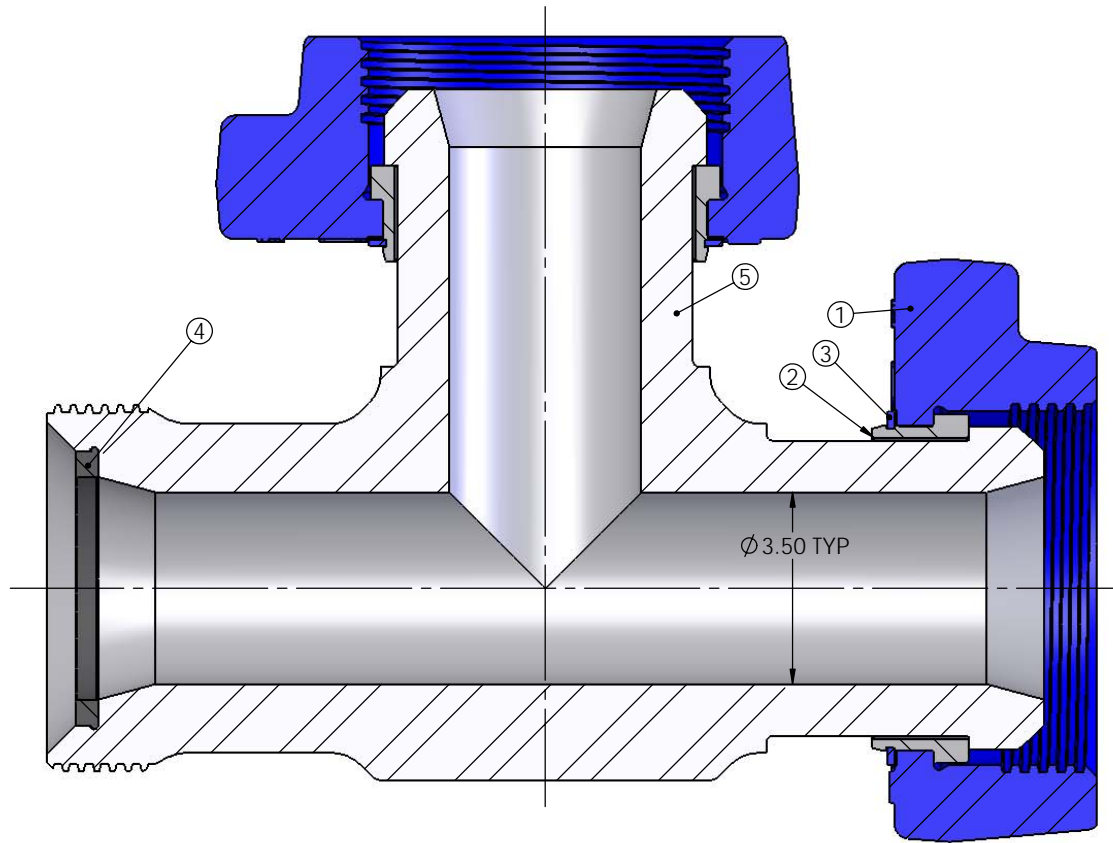

SECTION A-A



DRAWING STANDARDS:

- DIMENSION UNITS ARE INCHES
 1. ALL CORNER RADII R0.30
 2. BREAK ALL EDGES 0.015 X 45° OR R.015
 3. HIGBEE ALL ACME THREADS TO FULL WIDTH
 4. REFERENCE DIMENSIONS ARE IN PARENTHESIS
 5. MACHINED SURFACES ARE 125 Ra
 6. ALL DIAMETERS CONCENTRIC AND ROUND TO ± 0.005
 7. TOLERANCES: .XX ±0.015 < ±0.5°
 .XXX ±0.005

- < ±0.5° // PARALLELISM TOLERANCES: .XX ±0.015
 ○ ROUNDNESS ⊥ PERPENDICULARITY .XXX ±0.005
 ⊙ CONCENTRICITY ↗ RUNOUT < ±0.5°
 ⌀ CYLINDRICITY ⊔ COUNTERBORE UNLESS OTHERWISE STATED
 ▭ FLATNESS ∨ COUNTERSINK

ECN NO:	CHANGES INCLUDE:		REVISION:
ECN DATE:			0
MATERIAL SPEC:		TITLE: TEE, 4"1502 FMM STD 15K	DATE:
RAW MATERIAL DESC:		DWG NO. FTAC4FMM-S01	5/10/2006
WEIGHT: 211.02		DRAWN BY: SR CHK'D: JF APPV'D: KB	SHEET 2 OF 2

DO NOT SCALE DRAWING

THIS DRAWING IS PROPRIETARY AND CONFIDENTIAL PROPERTY. THIS DOCUMENT CANNOT BE REPRODUCED OR DISTRIBUTED WITHOUT THE WRITTEN CONSENT OF PHOINIX GLOBAL LLC.