

DRAWING STANDARDS:		TOLERANCES: .XX ±0.015	
DIMENSION UNITS ARE INCHES		.XXX ±0.005	
1. ALL CORNER RADII R0.30	∠ ±0.5°	// PARALLELISM	UNLESS OTHERWISE STATED
2. BREAK ALL EDGES 0.015 X 45° OR R.015	○ ROUNDNESS	⊥ PERPENDICULARITY	
3. HIGBEE ALL ACME THREADS TO FULL WIDTH	◎ CONCENTRICITY	↗ RUNOUT	
4. REFERENCE DIMENSIONS ARE IN PARENTHESIS	⊘ CYLINDRICITY	⊓ COUNTERBORE	
5. MACHINED SURFACES ARE 125 Ra	∇ FLATNESS	∨ COUNTERSINK	
6. ALL DIAMETERS CONCENTRIC AND ROUND TO ± 0.005			
7. TOLERANCES: .XX ±0.015 ∠ ±0.5°			
.XXX ±0.005			

ECN NO:	CHANGES INCLUDE:		
ECN DATE:			
MATERIAL SPEC:	TITLE: TEE, 4"1502 MMM STD 15K	REVISION:	0
RAW MATERIAL DESC:	DWG NO. FTAC4MMM-S01	DATE:	5/10/2006
WEIGHT: 246.89	DRAWN BY: SR	CHK'D: JF	APP'VD: KB
			SHEET 1 OF 2

DO NOT SCALE DRAWING

THIS DRAWING IS PROPRIETARY AND CONFIDENTIAL PROPERTY. THIS DOCUMENT CANNOT BE REPRODUCED OR DISTRIBUTED WITHOUT THE WRITTEN CONSENT OF PHOINIX GLOBAL LLC.

ITEM NO.	PART NUMBER	DESCRIPTION	QTY.
1	UWN-4C-D-S	WINGNUT, 4"1502 STD 15K DETACHABLE	3
2	UNRC4	NUT RETAINER, 4"1502	3
3	URRC4	RETAINER RING, 4"1502	3
4	FTBC4MMM-S01	TEE BODY, 4"1502 MMM STD 15K	1

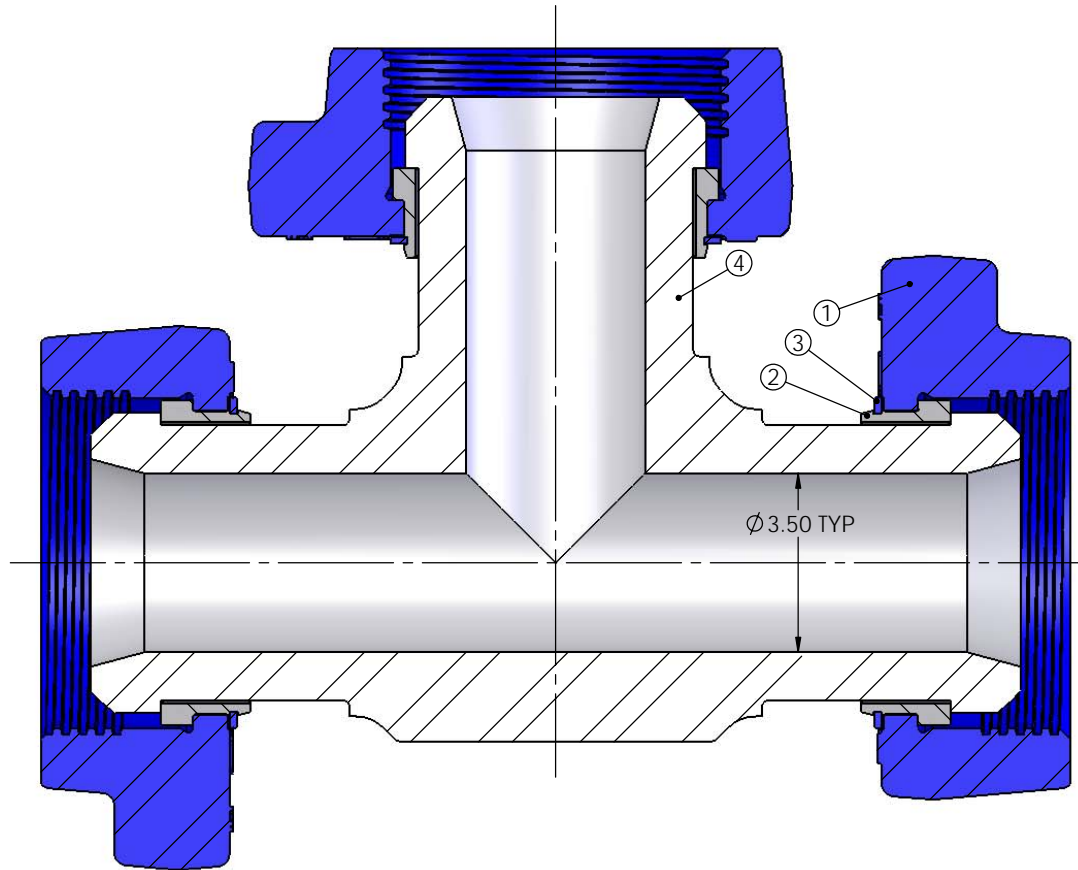

SECTION A-A



DRAWING STANDARDS:

DIMENSION UNITS ARE INCHES

1. ALL CORNER RADII R0.30
2. BREAK ALL EDGES 0.015 X 45° OR R.015
3. HIGBEE ALL ACME THREADS TO FULL WIDTH
4. REFERENCE DIMENSIONS ARE IN PARENTHESIS
5. MACHINED SURFACES ARE 125 Ra
6. ALL DIAMETERS CONCENTRIC AND ROUND TO ± 0.005
7. TOLERANCES: .XX ±0.015 $\leq \pm 0.5^\circ$
.XXX ±0.005

$\leq \pm 0.5^\circ$

○ ROUNDNESS

◎ CONCENTRICITY

⊘ CYLINDRICITY

▭ FLATNESS

// PARALLELISM

⊥ PERPENDICULARITY

↗ RUNOUT

□ COUNTERBORE

∨ COUNTERSINK

TOLERANCES: .XX ±0.015
.XXX ±0.005
$\leq \pm 0.5^\circ$
UNLESS OTHERWISE STATED

ECN NO:

CHANGES INCLUDE:

ECN DATE:

MATERIAL SPEC:

TITLE: TEE, 4"1502 MMM STD 15K

RAW MATERIAL DESC:

DWG NO. FTAC4MMM-S01

WEIGHT: 246.89

DRAWN BY: SR

CHK'D: JF

APPV'D: KB

REVISION:

0

DATE:

5/10/2006

SHEET 2 OF 2

DO NOT SCALE DRAWING

THIS DRAWING IS PROPRIETARY AND CONFIDENTIAL PROPERTY. THIS DOCUMENT CANNOT BE REPRODUCED OR DISTRIBUTED WITHOUT THE WRITTEN CONSENT OF PHOINIX GLOBAL LLC.