



## **Minimum Wall Inspection Criteria**

**11/28/2007**

**Rev. A**  
**Revision Date: 7/21/08**  
**(†) Updates**

## End Connections

Phoinix Global recommends regular inspection of equipment as part of a maintenance program.

The values given in this document are for Phoinix Global equipment only. End connections listed in the table are common to many different equipment manufacturers but the values should not be applied to other manufacturer's equipment or vice versa due to differences in material specifications.

All values listed in the table are for cold non-shock working pressure (CNSWP). Vibration, high and low temperatures, large pulsations and external loads can affect the integrity of the equipment and are beyond the scope of this paper. Applications where these conditions exist should warrant attention to the inspected equipment.

Phoinix Global recommends that trained personnel conduct all inspections with properly calibrated equipment. A good inspection should include a visual inspection as well as wall thickness readings. Visual inspections can spot localized erosion that could be possibly missed by "d-meter" readings alone.

<b>Phoinix Global Minimum Wall Thickness</b>		
<b>STD SERVICE ONLY</b>	Date: 10/5/2007	
<b>End Connection</b>	<b>New Wall</b>	<b>Minimum Wall</b>
1-1502 Male	<b>0.408</b>	<b>0.31</b>
1-1502 Female	<b>0.735</b>	<b>0.43</b>
1.5-1502 Male	<b>0.770</b>	<b>0.42</b>
1.5 1502 Female	<b>1.125</b>	<b>0.54</b>
2-1502 Male	<b>0.545</b>	<b>0.38</b>
2-1502 Female	<b>0.785</b>	<b>0.59</b>
3-1502 Male	<b>0.670</b>	<b>0.55</b>
3-1502 Female	<b>0.920</b>	<b>0.68</b>
4-1502 Male	<b>0.813</b>	<b>0.65</b>
4-1502 Female	<b>1.035</b>	<b>0.70</b>
4-1002 Male	<b>0.618</b>	<b>0.50</b>
4-1002 Female	<b>0.925</b>	<b>0.53</b>

## Flow line †

Flow line needs to have the end connections inspected as would any end connections. Additionally, any wash underneath the threaded sub should be carefully checked to insure that product integrity is intact.

Tubing wall thicknesses must be checked to the following values:

<b>Phoinix Global Minimum Wall Thickness</b>		
<b>STD SERVICE ONLY</b>		
<b>Flow Line</b>	<b>New Wall</b>	<b>Minimum Wall</b>
4-1002	<b>0.500</b>	<b>0.33</b>
4-1502	<b>0.625</b>	<b>0.54</b>

## Inspection Areas

### Male or Wing-half End Connections

1. Check along length of end connections
2. Check seal areas for corrosion that could affect seal function.

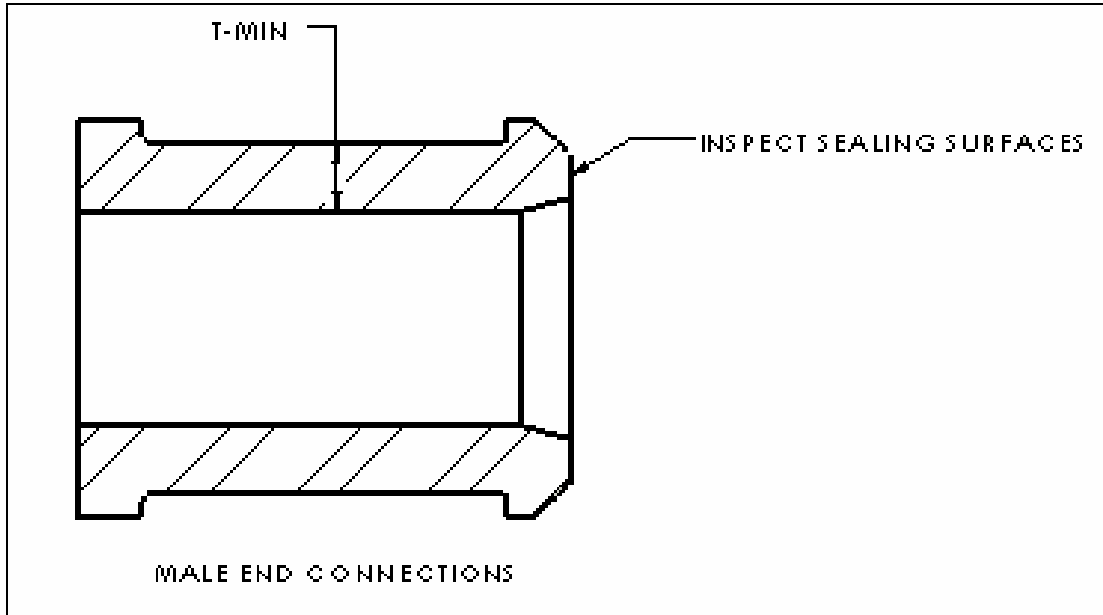

## Female or Thread-half End Connections

1. Check along length of end connections
2. Check seal areas for corrosion that could affect seal function.
3. Check Maximum Bore\*

\*Maximum bore establishes the shoulder which retains the resilient seal. Large bore sizes may compromise sealing while still meeting t-min requirements.

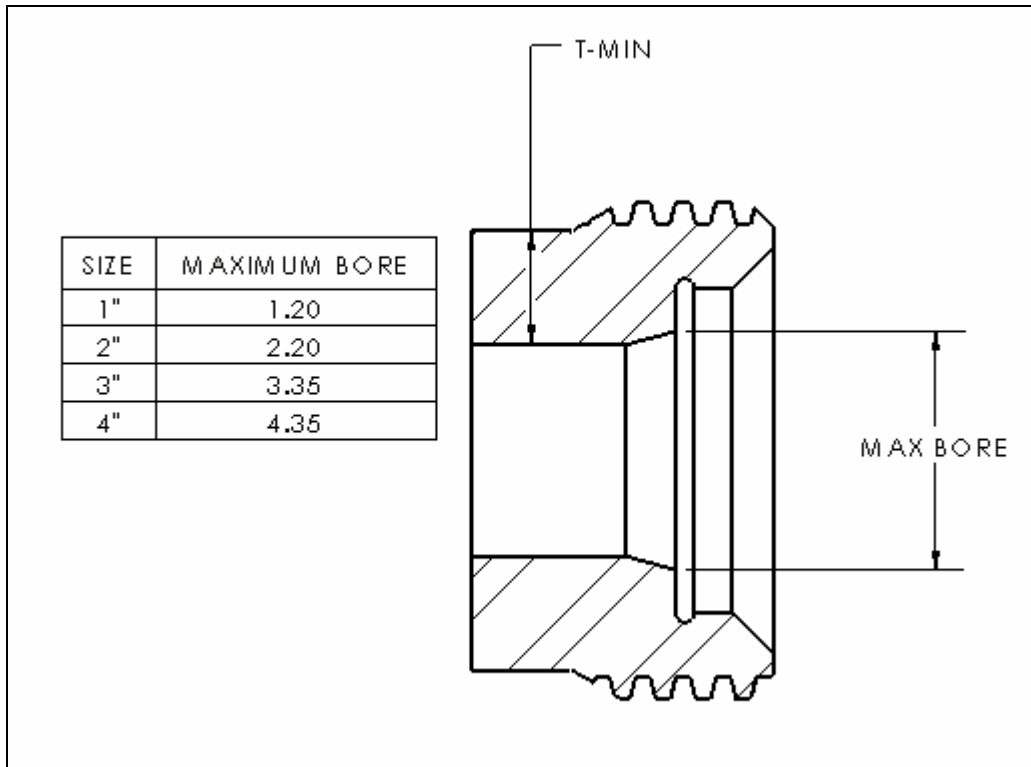

## Flow Line †

1. Check all NPST Subs for damage or corrosion
2. Check seal areas for corrosion that could affect seal function.
3. Check for wash under Subs
4. Check tubing wall thickness

