

**DRAWING STANDARDS:**

- 1. ALL CORNER RADII R0.30
- 2. BREAK ALL EDGES 0.015 X 45° OR R.015
- 3. HIGBEE ALL ACME THREADS TO FULL WIDTH
- 4. REFERENCE DIMENSIONS ARE IN PARENTHESIS
- 5. MACHINED SURFACES ARE 125 Ra
- 6. ALL DIAMETERS CONCENTRIC AND ROUND TO ± 0.005
- 7. TOLERANCES: .XX ±0.015 <math>\leq \pm 0.5^\circ</math>  
.XXX ±0.005

- $\angle \pm 0.5^\circ$
- $\parallel$  PARALLELISM
- $\bigcirc$  ROUNDNESS
- $\perp$  PERPENDICULARITY
- $\odot$  CONCENTRICITY
- $\curvearrowright$  RUNOUT
- $\text{Cyl}$  CYLINDRICITY
- $\sqcup$  COUNTERBORE
- $\square$  FLATNESS
- $\nabla$  COUNTERSINK

TOLERANCES: .XX ±0.015  
.XXX ±0.005  
<math>\leq \pm 0.5^\circ</math>  
UNLESS OTHERWISE STATED

ECN NO:	CHANGES INCLUDE:		
ECN DATE:			
MATERIAL SPEC:		TITLE: TEE, 2"1502 FFM STD 15K	REVISION: 0
RAW MATERIAL DESC:		DWG NO. FTAC2FFM-S01	DATE: 08/22/06
WEIGHT: 43.90	DRAWN BY: SR	CHK'D: JF	APP'VD: KB
			SHEET 1 OF 2

DO NOT SCALE DRAWING

THIS DRAWING IS PROPRIETARY AND CONFIDENTIAL PROPERTY. THIS DOCUMENT CANNOT BE REPRODUCED OR DISTRIBUTED WITHOUT THE WRITTEN CONSENT OF PHOINIX GLOBAL LLC.

ITEM	PART NUMBER	DESCRIPTION	QTY.
1	FTBC2FFM-S01	TEE BODY, 2"1502 FFM STD 15K	1
2	UWN-2C-D-S	WINGNUT, 2"1502 STD 15K DETACHABLE	1
3	UNRC2	NUT RETAINER, 2"1502	1
4	URRC2	RETAINER RING, 2"1502	1
5	USR2-S01	SEAL RING, 2"602/1002/1502 STD BUNA 90	2

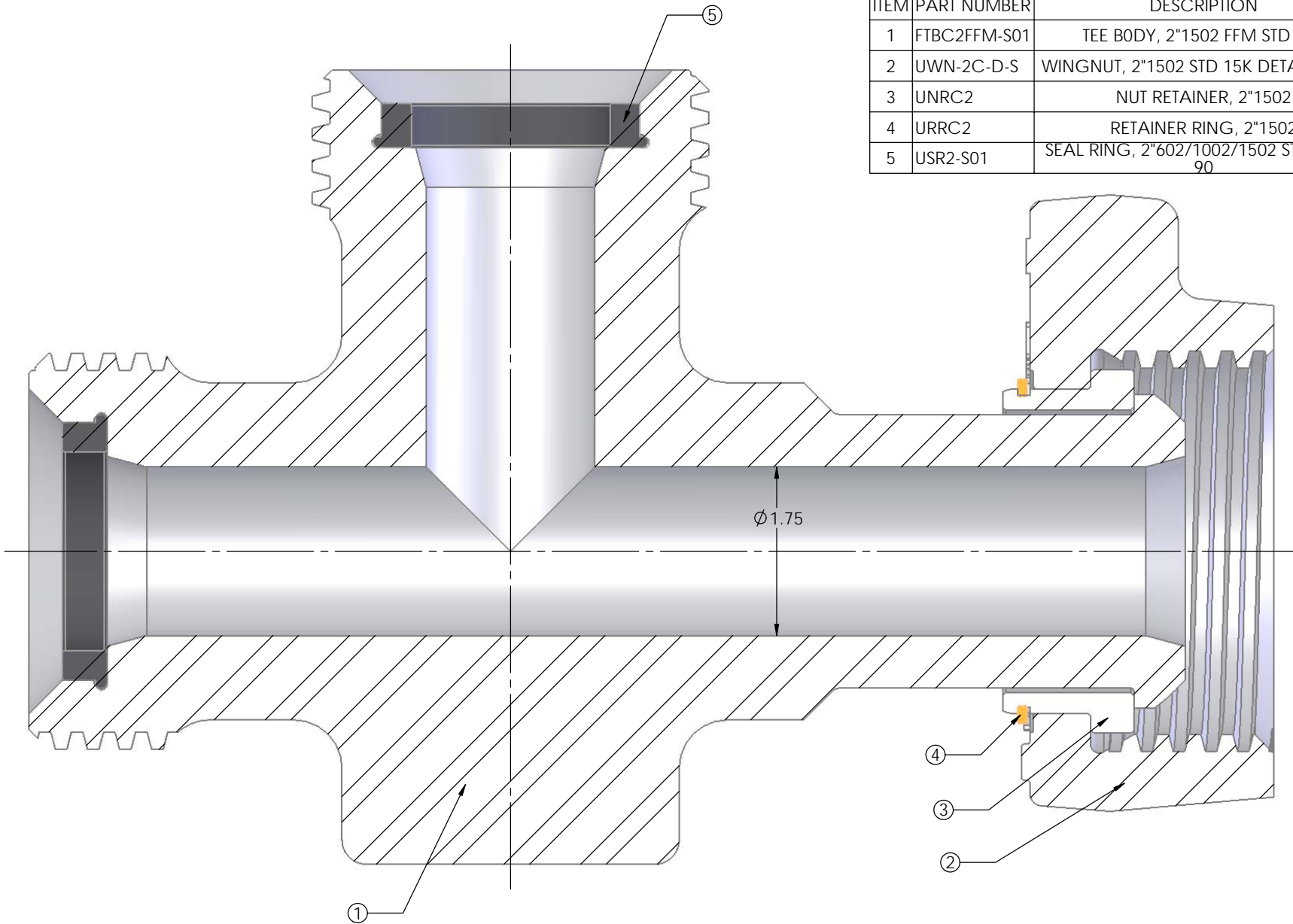

**DRAWING STANDARDS:**

DIMENSION UNITS ARE INCHES

- ALL CORNER RADII R0.30
- BREAK ALL EDGES 0.015 X 45° OR R.015
- HIGBEE ALL ACME THREADS TO FULL WIDTH
- REFERENCE DIMENSIONS ARE IN PARENTHESIS
- MACHINED SURFACES ARE 125 Ra
- ALL DIAMETERS CONCENTRIC AND ROUND TO ± 0.005
- TOLERANCES: .XX ±0.015 <math>\leq \pm 0.5^\circ</math>  
.XXX ±0.005

<math>\leq \pm 0.5^\circ</math>  
 ○ ROUNDNESS  
 ◎ CONCENTRICITY  
 ⌀ CYLINDRICITY  
 ▭ FLATNESS

// PARALLELISM  
 ⊥ PERPENDICULARITY  
 ↗ RUNOUT  
 ⊓ COUNTERBORE  
 ∨ COUNTERSINK

TOLERANCES: .XX ±0.015  
.XXX ±0.005  
<math>\leq \pm 0.5^\circ</math>  
UNLESS OTHERWISE STATED

ECN NO:	CHANGES INCLUDE:		
ECN DATE:			
MATERIAL SPEC:		TITLE: TEE, 2"1502 FFM STD 15K	REVISION: 0
RAW MATERIAL DESC:		DWG NO. FTAC2FFM-S01	DATE: 08/22/06
WEIGHT: 43.90		DRAWN BY: SR    CHK'D: JF    APP'V'D: KB	SHEET 2 OF 2

DO NOT SCALE DRAWING

THIS DRAWING IS PROPRIETARY AND CONFIDENTIAL PROPERTY. THIS DOCUMENT CANNOT BE REPRODUCED OR DISTRIBUTED WITHOUT THE WRITTEN CONSENT OF PHOINIX GLOBAL LLC.