

**DRAWING STANDARDS:**

- 1. ALL CORNER RADII R0.30
- 2. BREAK ALL EDGES 0.015 X 45° OR R.015
- 3. HIGBEE ALL ACME THREADS TO FULL WIDTH
- 4. REFERENCE DIMENSIONS ARE IN PARENTHESIS
- 5. MACHINED SURFACES ARE 125 Ra
- 6. ALL DIAMETERS CONCENTRIC AND ROUND TO ± 0.005
- 7. TOLERANCES: .XX ± 0.015 <math>\leq \pm 0.5^\circ</math>  
.XXX ± 0.005

- $\angle \pm 0.5^\circ$
- $\parallel$  PARALLELISM
- $\bigcirc$  ROUNDNESS
- $\perp$  PERPENDICULARITY
- $\odot$  CONCENTRICITY
- $\curvearrowright$  RUNOUT
- $\text{Cyl}$  CYLINDRICITY
- $\sqcup$  COUNTERBORE
- $\square$  FLATNESS
- $\nabla$  COUNTERSINK

TOLERANCES: .XX ± 0.015  
.XXX ± 0.005  
<math>\leq \pm 0.5^\circ</math>  
UNLESS OTHERWISE STATED

ECN NO:	CHANGES INCLUDE:		
ECN DATE:			
MATERIAL SPEC:	TITLE: CROSS, 2"1502 FM MM STD 15K		REVISION: 0
RAW MATERIAL DESC:	DWG NO. FXAC2FM MM-S01		DATE: 8/27/2006
WEIGHT: 68.33	DRAWN BY: KB	CHK'D: JG	APP'V'D: SR
			SHEET 1 OF 2

DO NOT SCALE DRAWING

THIS DRAWING IS PROPRIETARY AND CONFIDENTIAL PROPERTY. THIS DOCUMENT CANNOT BE REPRODUCED OR DISTRIBUTED WITHOUT THE WRITTEN CONSENT OF PHOINIX GLOBAL LLC.

ITEM NO.	PART NUMBER	DESCRIPTION	QTY.
1	FXBC2FMMM-S01	CROSS BODY, 2"1502 FMMM STD 15K	1
2	UWN-2C-D-S	WINGNUT, 2"1502 STD 15K DETACHABLE	3
3	UNRC2	NUT RETAINER, 2"1502	3
4	URRC2	RETAINER RING, 2"1502	3
5	USR2-S01	SEAL RING, 2"602/1002/1502 STD BUNA 90	1

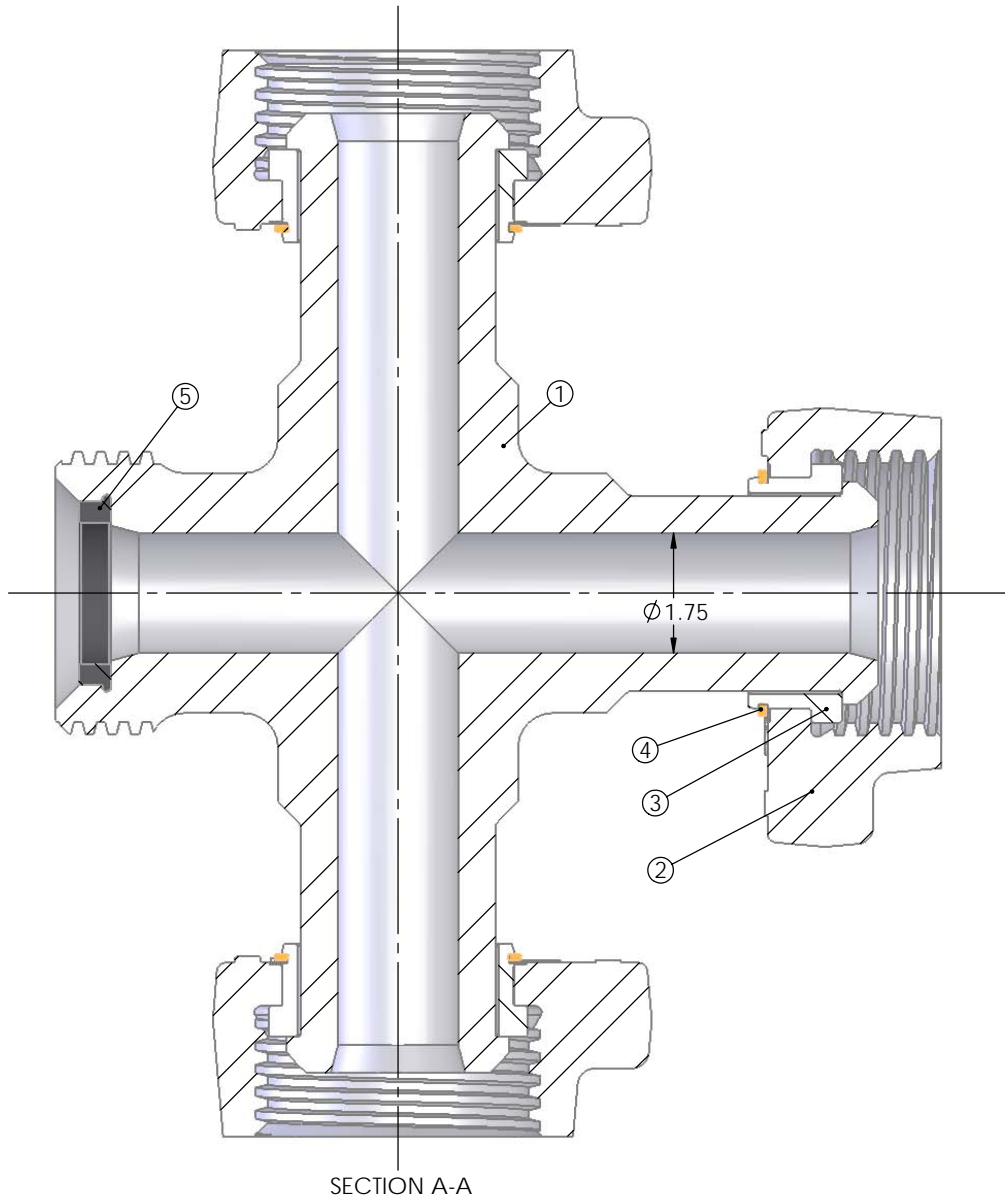

SECTION A-A



DRAWING STANDARDS:

DIMENSION UNITS ARE INCHES

1. ALL CORNER RADII R0.30
2. BREAK ALL EDGES 0.015 X 45° OR R.015
3. HIGBEE ALL ACME THREADS TO FULL WIDTH
4. REFERENCE DIMENSIONS ARE IN PARENTHESIS
5. MACHINED SURFACES ARE 125 Ra
6. ALL DIAMETERS CONCENTRIC AND ROUND TO ± 0.005
7. TOLERANCES: .XX ± 0.015 < ± 0.5°  
.XXX ± 0.005

< ± 0.5°

○ ROUNDNESS

◎ CONCENTRICITY

⊘ CYLINDRICITY

▭ FLATNESS

// PARALLELISM

⊥ PERPENDICULARITY

↗ RUNOUT

□ COUNTERBORE

∨ COUNTERSINK

TOLERANCES: .XX ± 0.015

.XXX ± 0.005

< ± 0.5°

UNLESS OTHERWISE STATED

ECN NO:

CHANGES INCLUDE:

ECN DATE:

MATERIAL SPEC:

TITLE: CROSS, 2"1502 FMMM STD 15K

RAW MATERIAL DESC:

DWG NO. FXAC2FMMM-S01

WEIGHT: 68.33

DRAWN BY: KB

CHK'D: JG

APPV'D: SR

REVISION:

0

DATE:

8/27/2006

SHEET 2 OF 2

DO NOT SCALE DRAWING

THIS DRAWING IS PROPRIETARY AND CONFIDENTIAL PROPERTY. THIS DOCUMENT CANNOT BE REPRODUCED OR DISTRIBUTED WITHOUT THE WRITTEN CONSENT OF PHOINIX GLOBAL LLC.