

ITEM NO.	PART NUMBER	DESCRIPTION	Qty
1	FTAC2MFM-S01	TEE, 2"1502 MFM STD 15K	1
2	VA1L-2CFM-S01	VALVE-LT, 1"x2"1502FM STD 15K	4
3	CAPC2FM-S01	CHOKE-POSITIVE, 2"1502 FM STD 15K	1
4	CAAC2FM-S01	CHOKE-ADJUSTABLE, 2"1502 FM STD 15K	1
5	SAC2FM-09.19-S01	SPACER, 2"1502 FM STD 15K x 9.19"	2
6	FTAC2FMM-S01	TEE, 2"1502 FMM STD 15K	2
7	FTAC2FMF-S01	TEE, 2"1502 FMF STD 15K	1
8	BA2CF-S01	BLANK ASSY, 2"1502 FEMALE STD 15K	2

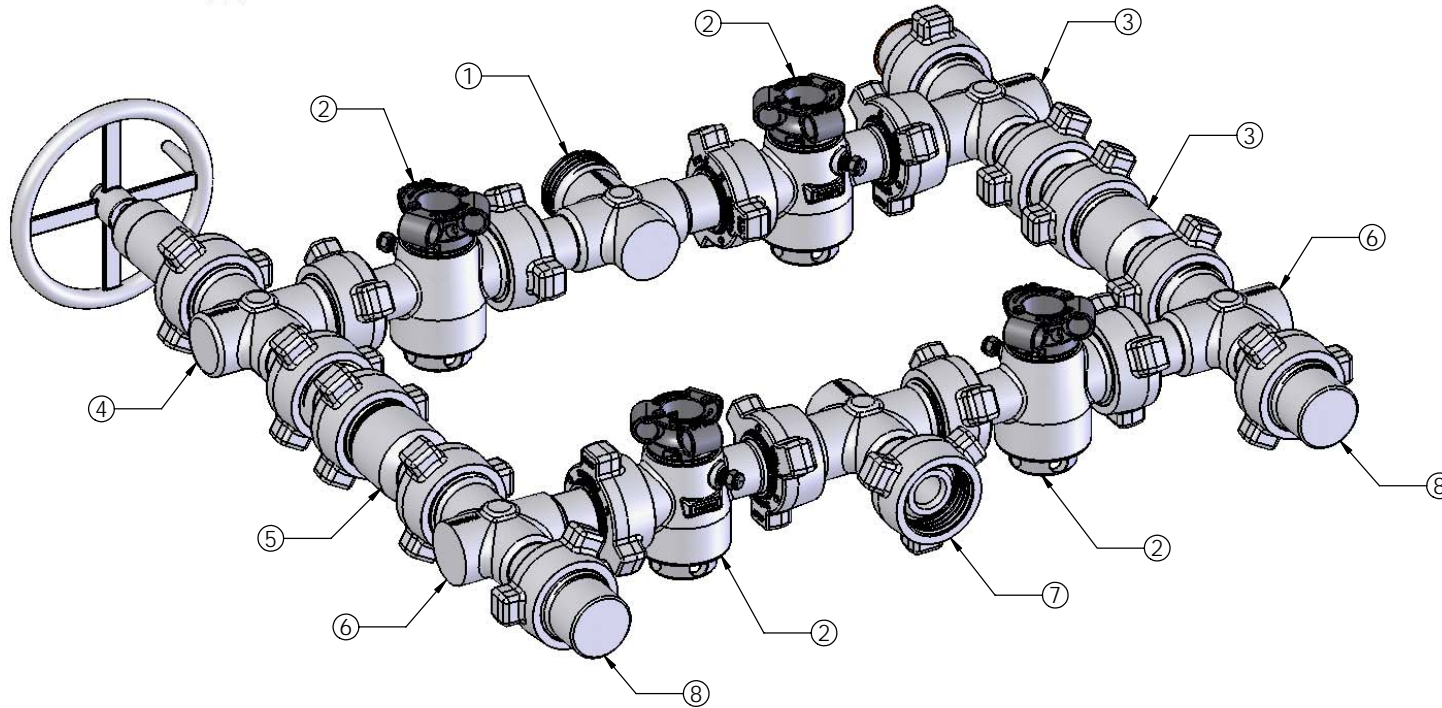

DRAWING STANDARDS:

DIMENSION UNITS ARE INCHES

1. ALL CORNER RADII R0.30
2. BREAK ALL EDGES 0.015 X 45° OR R.015
3. HIGBEE ALL ACME THREADS TO FULL WIDTH
4. REFERENCE DIMENSIONS ARE IN PARENTHESIS
5. MACHINED SURFACES ARE 125 Ra
6. ALL DIAMETERS CONCENTRIC AND ROUND TO ± 0.005
7. TOLERANCES: .XX ±0.015 $\leq \pm 0.5^\circ$
.XXX ±0.005

- $\angle \pm 0.5^\circ$
- ROUNDNESS
- ◎ CONCENTRICITY
- ⊘ CYLINDRICITY
- ▭ FLATNESS
- ∥ PARALLELISM
- ⊥ PERPENDICULARITY
- ↗ RUNOUT
- ▭ COUNTERBORE
- ∨ COUNTERSINK

TOLERANCES: .XX ±0.015
.XXX ±0.005
$\leq \pm 0.5^\circ$
UNLESS OTHERWISE STATED

ECN NO:

CHANGES INCLUDE:

ECN DATE:

MATERIAL SPEC:

RAW MATERIAL DESC:

WEIGHT: 679.17

TITLE: MANIFOLD, 1"LT BOX P/A-CHOKE STD 15K

DWG NO. MU-1L4-XPA-S01

DRAWN BY: SR CHK'D: JF APP'V'D: KB

REVISION:

0

DATE:

3/20/2007

SHEET 1 OF 2

DO NOT SCALE DRAWING

THIS DRAWING IS PROPRIETARY AND CONFIDENTIAL PROPERTY. THIS DOCUMENT CANNOT BE REPRODUCED OR DISTRIBUTED WITHOUT THE WRITTEN CONSENT OF PHOINIX GLOBAL LLC.

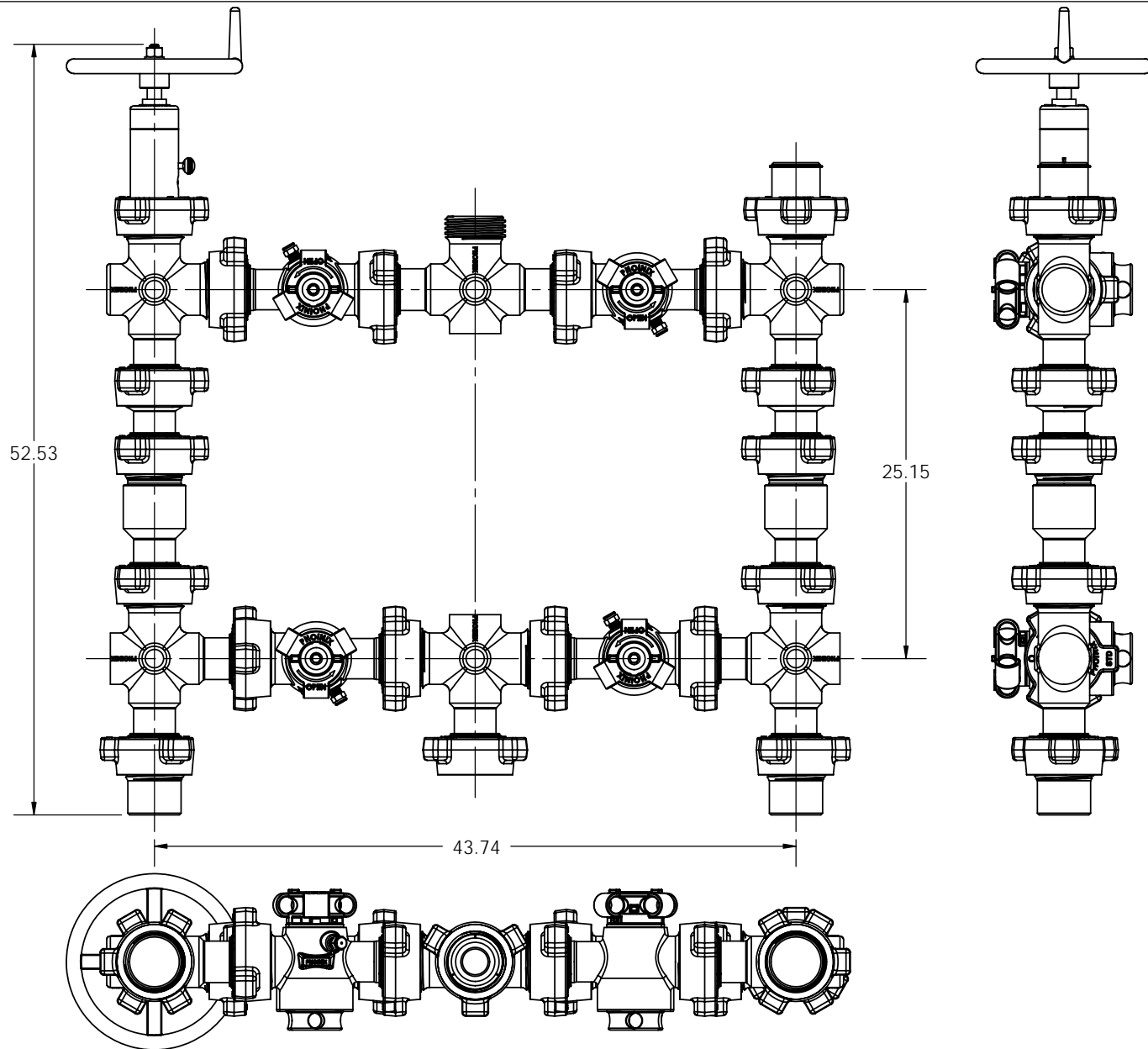

DRAWING STANDARDS:

- 1. ALL CORNER RADII R0.03
- 2. BREAK ALL EDGES 0.015 X 45° OR R.015
- 3. HIGBEE ALL ACME THREADS TO FULL WIDTH
- 4. REFERENCE DIMENSIONS ARE IN PARENTHESIS
- 5. MACHINED SURFACES ARE 125 Ra
- 6. ALL DIAMETERS CONCENTRIC AND ROUND TO ± 0.005
- 7. TOLERANCES: .XX ± 0.015 < ± 0.5°
.XXX ± 0.005

- < ± 0.5°
- ROUNDNESS
- ◎ CONCENTRICITY
- ∕∕ CYLINDRICITY
- ▭ FLATNESS
- ∕∕ PARALLELISM
- ⊥ PERPENDICULARITY
- ↗ RUNOUT
- ▭ COUNTERBORE
- ∨ COUNTERSINK

TOLERANCES: .XX ± 0.015
.XXX ± 0.005
< ± 0.5°
UNLESS OTHERWISE STATED

ECN NO:	CHANGES INCLUDE:		
ECN DATE:			
MATERIAL SPEC:	TITLE: MANIFOLD, 1" LT BOX P/A-CHOKE STD 15K		REVISION: 0
RAW MATERIAL DESC:	DWG NO. MU-1L4-XPA-S01		DATE: 3/20/2007
WEIGHT: 679.17	DRAWN BY: SR	CHK'D: JF	APP'VD: KB
			SHEET 2 OF 2

DO NOT SCALE DRAWING

THIS DRAWING IS PROPRIETARY AND CONFIDENTIAL PROPERTY. THIS DOCUMENT CANNOT BE REPRODUCED OR DISTRIBUTED WITHOUT THE WRITTEN CONSENT OF PHOINIX GLOBAL LLC.