

DRAWING STANDARDS:

DIMENSION UNITS ARE INCHES

1. ALL CORNER RADII R0.30
2. BREAK ALL EDGES 0.015 X 45° OR R.015
3. HIGBEE ALL ACME THREADS TO FULL WIDTH
4. REFERENCE DIMENSIONS ARE IN PARENTHESIS
5. MACHINED SURFACES ARE 125 Ra
6. ALL DIAMETERS CONCENTRIC AND ROUND TO ± 0.005
7. TOLERANCES: .XX ± 0.015 $\leq \pm 0.5^\circ$
.XXX ± 0.005 $\leq \pm 0.5^\circ$

$\leq \pm 0.5^\circ$ // PARALLELISM TOLERANCES: .XX ± 0.015
 ○ ROUNDNESS ⊥ PERPENDICULARITY .XXX ± 0.005
 ◎ CONCENTRICITY ↗ RUNOUT $\leq \pm 0.5^\circ$ UNLESS OTHERWISE STATED
 ∅ CYLINDRICITY ⊓ COUNTERBORE
 ▭ FLATNESS ∇ COUNTERSINK

ECN NO:	CHANGES INCLUDE:	MATERIAL SPEC:	TITLE: VALVE-LT, 2"x2"1502FM STD 15K ACTUATED (HYD)	REVISION:
ECN DATE:				0
RAW MATERIAL DESC:		DWG NO. VA2L-2CFM-AH-S01		DATE:
WEIGHT: 102.93				3/28/2007
DRAWN BY: KB		CHK'D: JG	APP'D: SR	SHEET 1 OF 2

DO NOT SCALE DRAWING

THIS DRAWING IS PROPRIETARY AND CONFIDENTIAL PROPERTY. THIS DOCUMENT CANNOT BE REPRODUCED OR DISTRIBUTED WITHOUT THE WRITTEN CONSENT OF PHOINIX GLOBAL LLC.

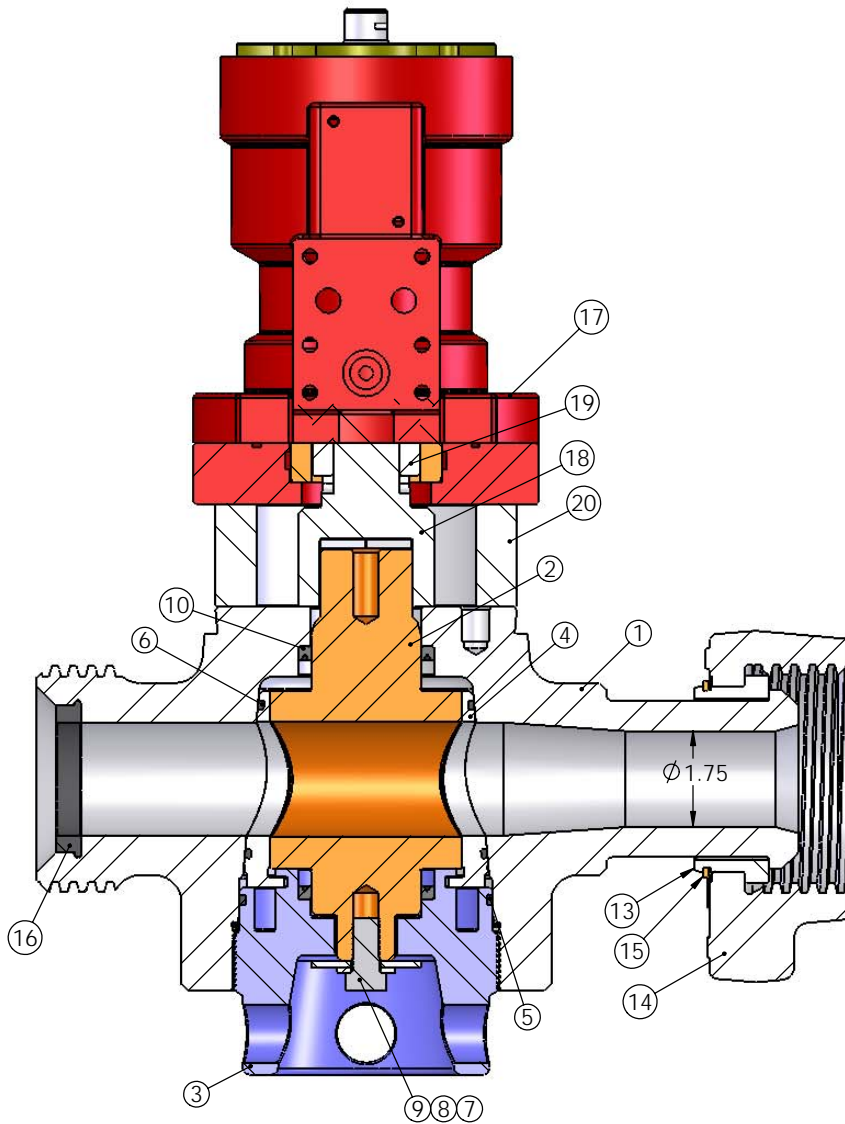

SECTION A-A

ITEM NO.	PART NUMBER	DESCRIPTION	QTY.
1	VB2L-2CFM-S01	VLV BODY-LT, 2"x2"1502FM STD 15K	1
2	VP2L-S01	VALVE PLUG, 2"LT STD	1
3	VAN2L-H01	VALVE ADJUSTING NUT, 2" H2S	1
4	VIN2L	VALVE INSERT, 2"LT STD	1
5	VOR2L-A-S01	VALVE O-RING, 2" STD BUNA 90 (ADJ NUT)	1
6	VOR2L-I-S01	VALVE O-RING, 2" STD BUNA 90 (INSERT)	2
7	F-WFF-0.500	WASHER, FLAT FENDER 1/2"	1
8	F-WFS-0.500	WASHER, FLAT STD 1/2"	1
9	F-HHC0.50-20X1.00-G8	CAP SCREW, HEX HD 1/2"-20 x 01.00"LONG	1
10	VPS2L-S01	VALVE PLUG SEAL, 2" & 3" STD BRASS/BUNA 90	2
11	F-RP0.313X0.75	ROLL PIN, 5/16"DIA x 3/4"LONG (PLAIN STEEL)	2
12	GF001	GREASE FITTING, 3/4"-10 GIANT BUTTON HEAD H2S	1
13	UNRC2	NUT RETAINER, 2"1502	1
14	UWN-2C-D-S	WINGNUT, 2"1502 STD 15K DETACHABLE	1
15	URRC2	RETAINER RING, 2"1502	1
16	USR2-S01	SEAL RING, 2"602/1002/1502 STD BUNA 90	1
17	AC-BRC1000	ACTUATOR, DANFOSS BRC1000 w/MOUNTING	1
18	AA-HEXB01	ACT ADAPTER, HEX "B" TO 1.88" SHAFT/KEYWAY	1
19	F-KS0.375X2.00	KEY STOCK, 3/8" x 2.00"LONG	2
20	AP002	ACTUATOR PLATE, DANFOSS BRC1000 2" HEX	1
21	F-SHC0.38-16X2.75-G5	CAP SCREW, SOC HD 3/8"-16 x 02.75"LONG	4
22	F-WLH-0.38	WASHER, LOCKING HIGH-COLLAR 3/8"	4



DRAWING STANDARDS:

DIMENSION UNITS ARE INCHES
 1. ALL CORNER RADII R0.03
 2. BREAK ALL EDGES 0.015 X 45° OR R.015
 3. HIGBEE ALL ACME THREADS TO FULL WIDTH
 4. REFERENCE DIMENSIONS ARE IN PARENTHESIS
 5. MACHINED SURFACES ARE 125 Ra
 6. ALL DIAMETERS CONCENTRIC AND ROUND TO ± 0.005
 7. TOLERANCES: .XX ± 0.015 < ± 0.5°
 .XXX ± 0.005

∠ ± 0.5° // PARALLELISM
 ○ ROUNDNESS ⊥ PERPENDICULARITY
 ◎ CONCENTRICITY ↗ RUNOUT
 ∅ CYLINDRICITY ⊓ COUNTERBORE
 ▭ FLATNESS ∇ COUNTERSINK

TOLERANCES: .XX ± 0.015
 .XXX ± 0.005
 < ± 0.5°
 UNLESS OTHERWISE STATED

ECN NO: CHANGES INCLUDE:

ECN DATE:

MATERIAL SPEC:

RAW MATERIAL DESC:

WEIGHT: 102.93

TITLE: VALVE-LT, 2"x2"1502FM STD 15K ACTUATED (HYD)

DWG NO. VA2L-2CFM-AH-S01

DRAWN BY: KB CHK'D: JG APP'V'D: SR

REVISION:

0

DATE:

3/28/2007

DO NOT SCALE DRAWING

THIS DRAWING IS PROPRIETARY AND CONFIDENTIAL PROPERTY. THIS DOCUMENT CANNOT BE REPRODUCED OR DISTRIBUTED WITHOUT THE WRITTEN CONSENT OF PHOINIX GLOBAL LLC.

SHEET 2 OF 2