

DRAWING STANDARDS:

DIMENSION UNITS ARE INCHES

1. ALL CORNER RADII R0.30
2. BREAK ALL EDGES 0.015 X 45° OR R.015
3. HIGBEE ALL ACME THREADS TO FULL WIDTH
4. REFERENCE DIMENSIONS ARE IN PARENTHESIS
5. MACHINED SURFACES ARE 125 Ra
6. ALL DIAMETERS CONCENTRIC AND ROUND TO ±0.005
7. TOLERANCES: .XX ±0.015 < ±0.5°
.XXX ±0.005 < ±0.5°

- < ±0.5°
- ROUNDNESS
- ◎ CONCENTRICITY
- ∕ CYLINDRICITY
- ▭ FLATNESS
- ∕∕ PARALLELISM
- ⊥ PERPENDICULARITY
- ↗ RUNOUT
- ⊓ COUNTERBORE
- ∨ COUNTERSINK

TOLERANCES: .XX ±0.015
.XXX ±0.005
< ±0.5°
UNLESS OTHERWISE STATED

ECN NO:

CHANGES INCLUDE:

ECN DATE:

MATERIAL SPEC:

RAW MATERIAL DESC:

WEIGHT: 368.32

TITLE: VALVE-LT, 3"x3 1/16" FLGxSTUD 15K STD MANUAL

DWG NO. VA3L-F3C-SF3C-S01

DRAWN BY: SR CHK'D: JF APPV'D: KB

REVISION:
0
DATE:
2/5/2008

SHEET 1 OF 2

DO NOT SCALE DRAWING

THIS DRAWING IS PROPRIETARY AND CONFIDENTIAL PROPERTY. THIS DOCUMENT CANNOT BE REPRODUCED OR DISTRIBUTED WITHOUT THE WRITTEN CONSENT OF PHOINIX GLOBAL LLC.

ITEM NO.	PART NUMBER	DESCRIPTION	QTY.
1	VB3L-F3C-SF3C-S01	VLV BODY-LT, 3"x3 1/16 FLGxSTUD 15K STD	1
2	VP3L-S01	PLUG-LT, 3" STD	1
3	VAN3L	VALVE ADJUSTING NUT, 3" LT H2S	1
4	VIN3L-S01	INSERT SET-LT, 3" STD	1
5	F-RP0.313X0.75	ROLL PIN, 5/16"DIA x 3/4"LONG (PLAIN STEEL)	4
6	VOR3L-I-S01	VALVE O-RING, 3" STD BUNA 90 (INSERT)	2
7	VPS2L-S01	VALVE PLUG SEAL, 2" & 3" STD BRASS/BUNA 90	2
8	VOR3L-A-S01	VALVE O-RING, 3" STD BUNA 90 (ADJ NUT)	1
9	F-HHC0.50-20X1.00-G8	CAP SCREW, HEX HD 1/2"-20 x 01.00"LONG	2
10	F-WFF-0.500	WASHER, FLAT FENDER 1/2"	2
11	F-WFS-0.500	WASHER, FLAT STD 1/2"	2
12	VH2L	VALVE HANDLE 2"	1
13	F-SS0.375X0.75-D	SET SCREW, SOCKET HD 3/8"-16 x 0.75"LONG DOGPOINT	2
14	F-SHC0.50-13X0.63-G5	CAP SCREW, SOC HD 1/2"-13 x 00.50"LONG	1
15	GF001	GREASE FITTING, 3/4"-10 GIANT BUTTON HEAD H2S	2
16	F-FST-3-15K	FLANGE STUD-TAP END, 3 1/16 15K (1 1/8-8)	8

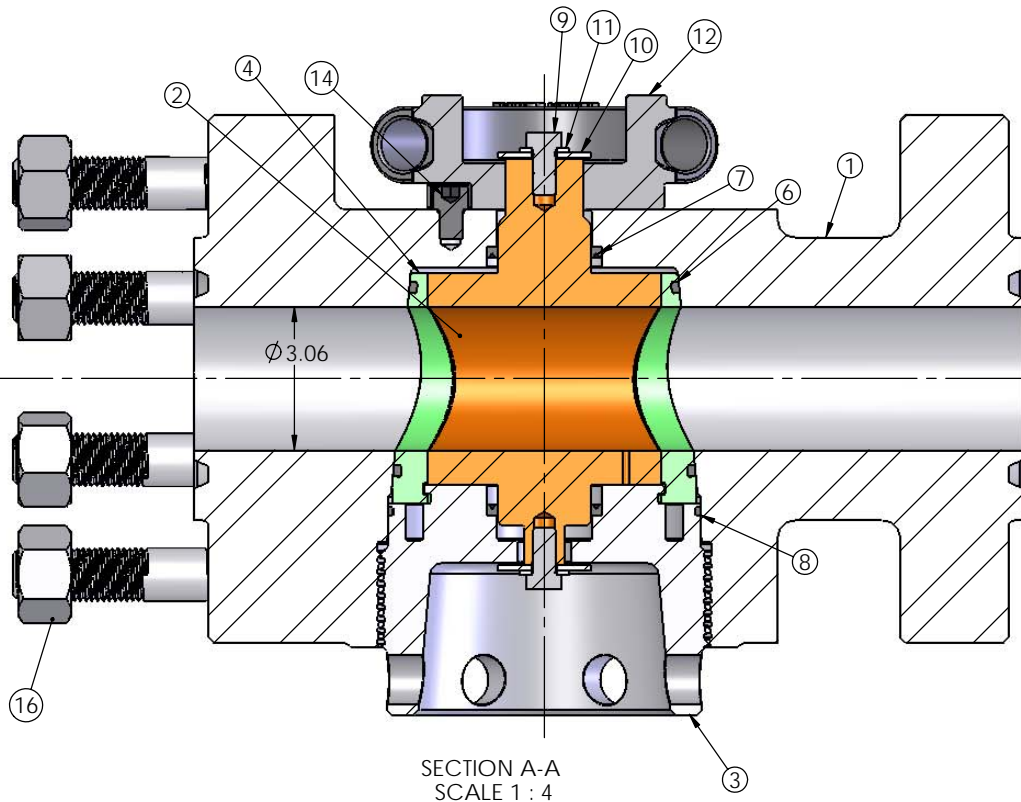

DRAWING STANDARDS:

DIMENSION UNITS ARE INCHES

- 1. ALL CORNER RADII R0.03
- 2. BREAK ALL EDGES 0.015 X 45° OR R.015
- 3. HIGBEE ALL ACME THREADS TO FULL WIDTH
- 4. REFERENCE DIMENSIONS ARE IN PARENTHESIS
- 5. MACHINED SURFACES ARE 125 Ra
- 6. ALL DIAMETERS CONCENTRIC AND ROUND TO ± 0.005
- 7. TOLERANCES: .XX ± 0.015 < ± 0.5°
.XXX ± 0.005 < ± 0.5°

- < ± 0.5°
- ROUNDNESS
- ◎ CONCENTRICITY
- ∕ CYLINDRICITY
- ▭ FLATNESS
- ∕∕ PARALLELISM
- ⊥ PERPENDICULARITY
- ↗ RUNOUT
- ⊓ COUNTERBORE
- ∨ COUNTERSINK

TOLERANCES: .XX ± 0.015
.XXX ± 0.005
< ± 0.5°
UNLESS OTHERWISE STATED

ECN NO:

CHANGES INCLUDE:

ECN DATE:

MATERIAL SPEC:

RAW MATERIAL DESC:

WEIGHT: 368.32

TITLE: VALVE-LT, 3"x3 1/16" FLGxSTUD 15K STD MANUAL

DWG NO. VA3L-F3C-SF3C-S01

DRAWN BY: SR CHK'D: JF APPV'D: KB

REVISION:
0
DATE:
2/5/2008

SHEET 2 OF 2

DO NOT SCALE DRAWING

THIS DRAWING IS PROPRIETARY AND CONFIDENTIAL PROPERTY. THIS DOCUMENT CANNOT BE REPRODUCED OR DISTRIBUTED WITHOUT THE WRITTEN CONSENT OF PHOINIX GLOBAL LLC.